

Technical Publications Web Site Interactive Maintenance Library Online Manuals User's Guide

Illustrated Parts Catalogs, Wiring Manuals, Maintenance Manuals, Structural Inspection Manuals, Airworthiness Limitations Manuals, Printed Circuit Board Manuals, Maintenance Schedules and all other technical publications included with Interactive Maintenance Library (IML) CD's are available on the web. To access the IML Online Manuals, you must be an active subscriber and registered on the website. To be able to order Hawker Beechcraft Parts & Distribution (formerly known as Rapid) parts from the parts catalogs, make sure you are signed up with an HBP&D account.

The Technical Publications website is located at <http://pubs.hawkerbeechcraft.com>. The Technical Publications site can also be accessed by going to the Hawker Beechcraft home page (<http://www.hawkerbeechcraft.com>), click on Global Customer Support, Technical Publications, then the submenu Overview). To view technical data (including technical manuals) users need to create a web account. This is a one-time, no charge set-up. For more information on registering on the site, refer to the Web Site Registration User's Guide located in the Help/FAQ section of the Tech Pubs web site.

Online Manuals can be accessed by clicking on the **IML Online Manuals** link on the Tech Pubs home page (overview). It can also be accessed by clicking on the IML Online Manuals link on the left-hand side of the screen from any Tech Pubs page.

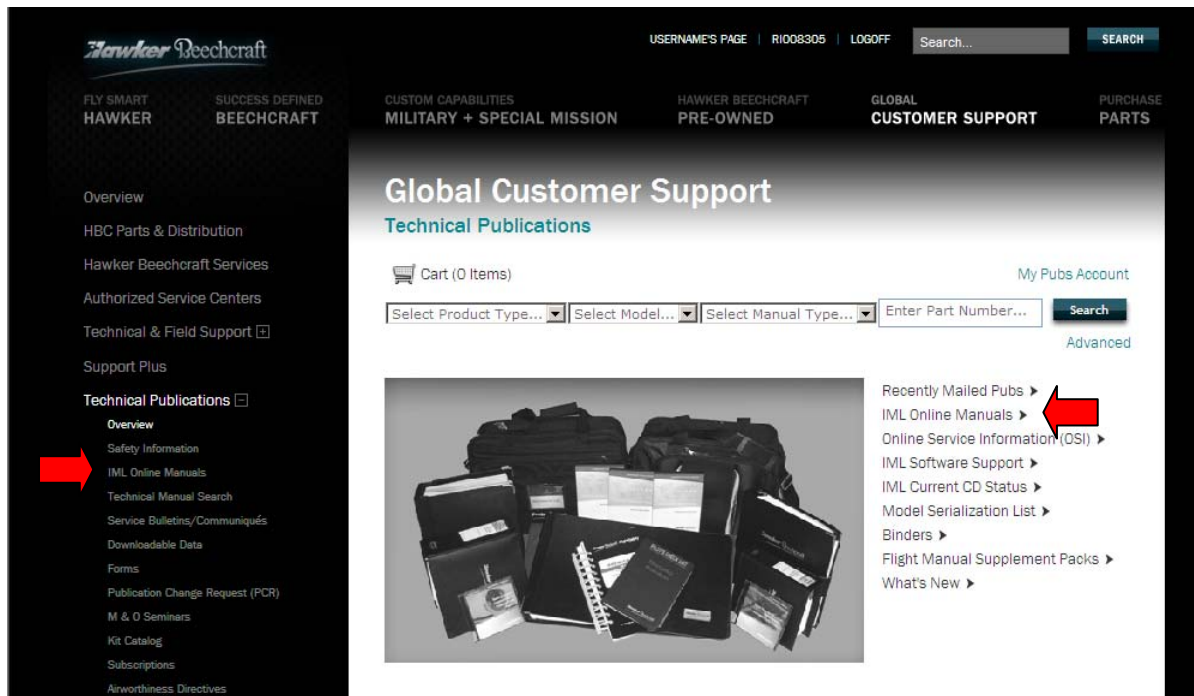

The manuals you currently subscribe to are listed in the drop-down menu. Click on the desired model to list those manuals. This menu also gives the part number, revision status and date of each manual. Click on **View** to open a specific manual.

Technical Publications
IML Online Manuals

Cart (0 Items)

Select Product Type... Select Model... Select...

Click here for information on ordering additional manuals.

Click here for the IML Online Manual's Guide.

Show Model Group: Hawker 400XP

Book	Part Number	Revision/Date	Type
View Airworthiness Limitations Manual	128-590001-305	B REISSUE 30 SEPT 2005	Maintenance
View RVSM Data Package	RVSM DATA - 400A		Misc
View Wiring Diagram Manual (400A) (RK-45, RK-49 and After)	128-590001-147	C1 DEC 2007	Wiring
View Maintenance Manual (Mar 2010 TR 05-3)	128-590001-9	C22 JAN 2010	Maintenance
View Structural Repair Manual	128-590001-17	C10 JUL 2009	SRM
View Illustrated Parts Catalog	128-590001-11	L REISSUE JAN 2010	IPC

The Table of Contents menu for that specific manual appears which contains links to the various chapters.

IML WebView - Model 400/400A Illustrated Parts Catalog - Windows Internet Explorer

http://webapps.hawkerbeechcraft.com/Manuals/book.aspx?book=rayairco/400IPC

Home | Search | Zoom | Display | Add to Cart | View Cart | Help

Click to Filter by Aircraft Serial No.

Hawker Beechcraft

Model 400/400A
Illustrated Parts Catalog
Part Number: 128-590001-11

Title Page (Serial Effectivity)
Introduction

Search [] [SEARCH] (Part Number/Description)

Filter by Aircraft [] [FILTER]

Prefix [RJ] Serial No (Ex: 999) []

11 Placards & Markings	38 Water/Waste
21 Environmental/Air Conditioning	39 Electrical Panels, Parts & Instruments
22 Auto Flight	52 Doors
23 Communications	53 Fuselage
24 Electrical Power	54 Nacelles/Pylons
25 Equipment/Furnishings	55 Stabilizers
26 Fire Protection	56 Windows
27 Flight Controls	57 Wings
28 Fuel	71 Power Plant
29 Hydraulic Power	73 Engine Fuel & Control
30 Ice & Rain Protection	76 Engine Controls
31 Indicating/Recording Systems	77 Engine Indicating
32 Landing Gear	78 Exhaust
33 Lights	79 Oil
34 Navigation/Pitot Static	80 Starting
35 Oxygen	
36 Pneumatic	

Navigation

To navigate and access features, use the IML Toolbar located below the Internet Explorer Menubar.



Note: Do not use the Internet Explorer Standard Toolbar unless you want to close the Window. To return to the Online Manuals menu, click on the IML Toolbar X.

Active Icon buttons are available for navigation, printing, searching, etc. Hold the mouse cursor over a button to provide a tool-tip that identifies the function of the button or pulls down additional features.

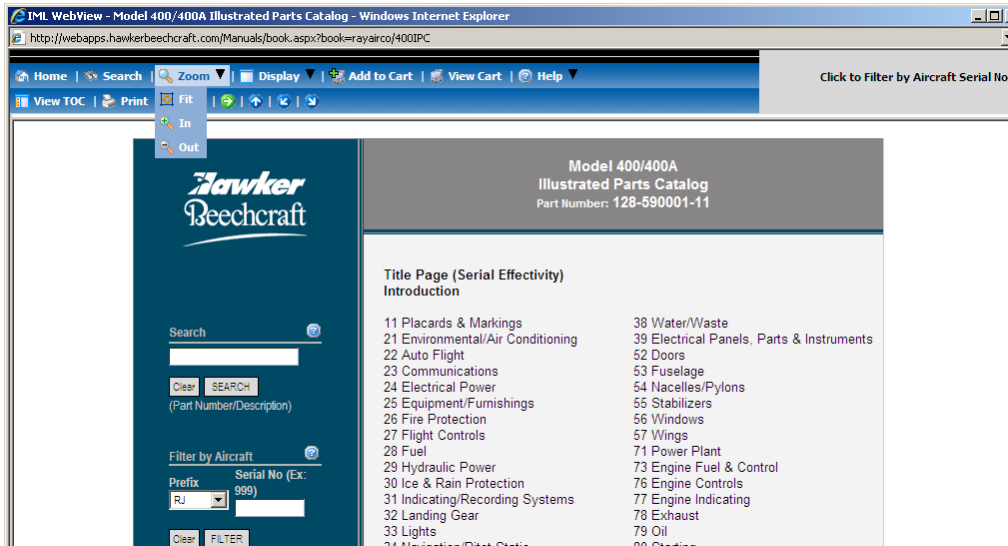

Home

Returns back to the Online Manuals Main Menu.

Search

Enter the part number or part description (fragments may be used) then click **Search**. Clicking the  next to Help provides a pop-up with How-to-Perform searches.

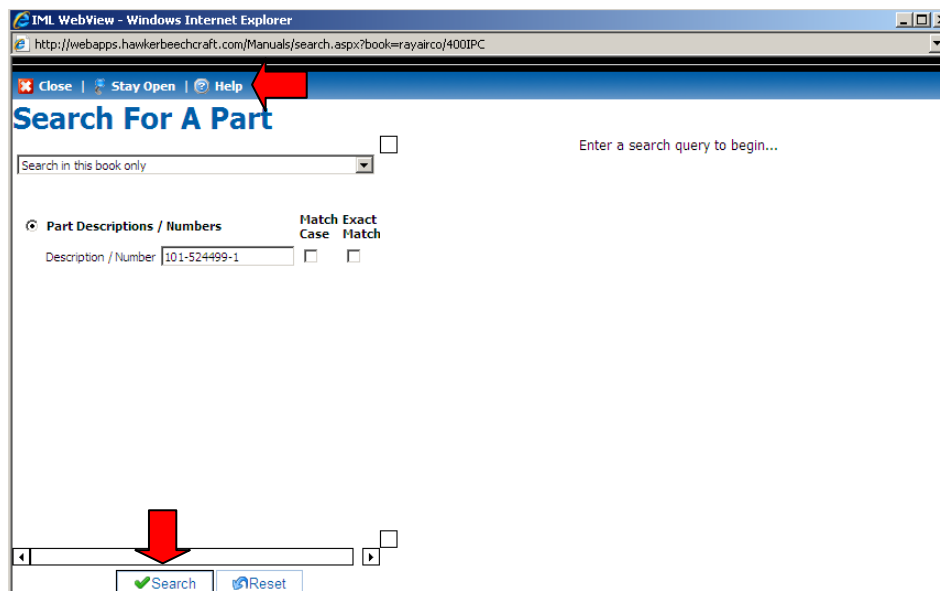

Searches can also be performed from the book menu.

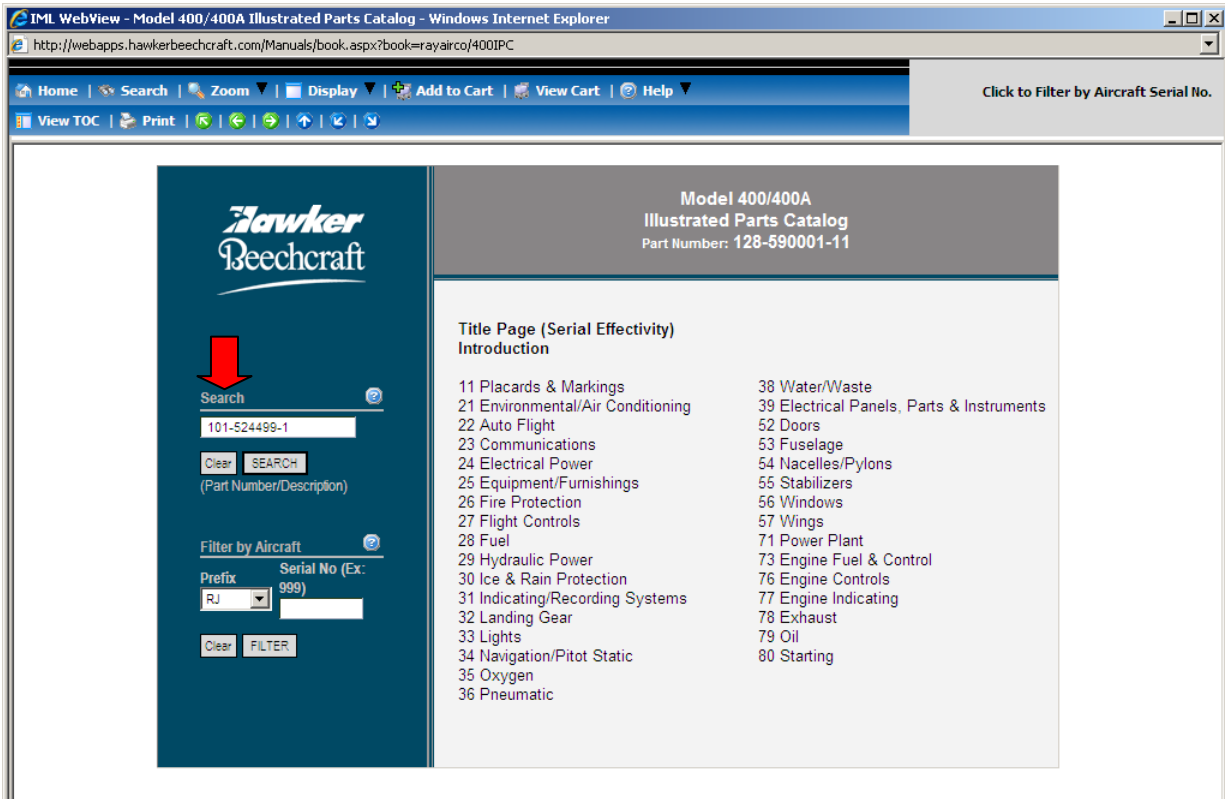

Zoom

Three magnification levels are available: fit to page, zoom in and zoom out.



Display

Displays the table of contents, illustrations, parts list and shopping cart.



View TOC

Selects or deselects the table of contents.

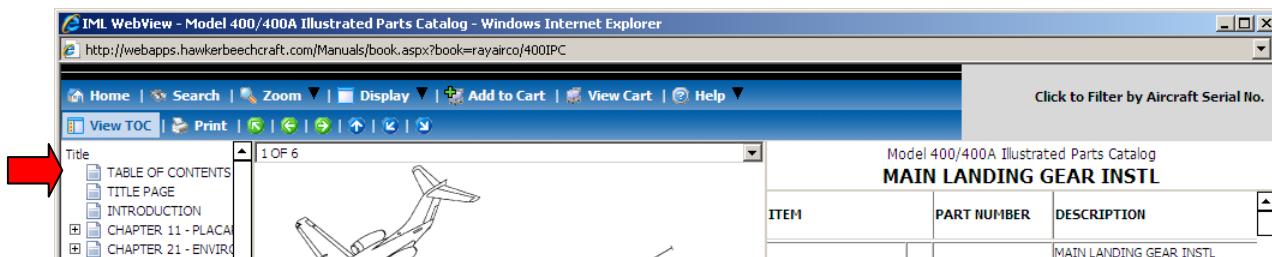

Parts Catalog Cart (Selected Parts List)

Detailed User Instructions are in the Comprehensive User Guide. See Appendix 2 for website support and additional contact information.

The screenshot shows the IML WebView interface for the Model 400/400A Illustrated Parts Catalog. The main heading is "MAIN LANDING GEAR INSTL". The parts list table is as follows:

ITEM	PART NUMBER	DESCRIPTION
<input type="checkbox"/>	5 128-810033-3	MAIN LANDING GEAR INSTL LANDING GEAR INSTL-MAIN,LH FOR ADDITIONAL DETAILS SEE: 32-40-05-01
<input type="checkbox"/>	6 128-810033-4	LANDING GEAR INSTL-MAIN,RH FOR ADDITIONAL DETAILS SEE: 32-40-05-01
<input type="checkbox"/>	10 128-810092-1	PIN
<input type="checkbox"/>	15 45A97602-017	SHIM
<input type="checkbox"/>	20 45A97602-019	SHIM
<input checked="" type="checkbox"/>	25 NAS1107-40	BOLT- ALTERNATE SPARE: NAS6207-40
<input type="checkbox"/>	25 NAS6207-40	BOLT- ALTERNATE SPARE: NAS1107-40

Below the table is a summary table:

Part Number	Description	Qty	Book	CSUF	Item	Comments
128-810092-1	PIN	1	Beechjet/400XP IPC	32-10-01-01	10	
45A97602-017	SHIM	1	Beechjet/400XP IPC	32-10-01-01	15	
45A97602-019	SHIM	1	Beechjet/400XP IPC	32-10-01-01	20	
NAS1107-40	BOLT-	1	Beechjet/400XP IPC	32-10-01-01	25	

Add to Cart

Adds selected items to the shopping cart.

View Cart

Selects or deselects the shopping cart.

Help

IML Help contains information on navigation buttons, searches, filters and notes. **About This Book** gives the current book's title, part number, revision status and date. **About IML** gives the current WebView version information. If you cannot find the information in the help documentation, contact the IML Helpline (contacts are listed at the end of this document).



Print

Prints the entire parts list with the option to print the graphic displayed or all illustrations. Details printing instructions are in Appendix 1 of this User's Guide.

Printing Defaults:

Paper Size = 8.5x11

Image Size = 100%

Orientation = Portrait

Settings can be changed using the printer dialog box.

Navigation Arrows

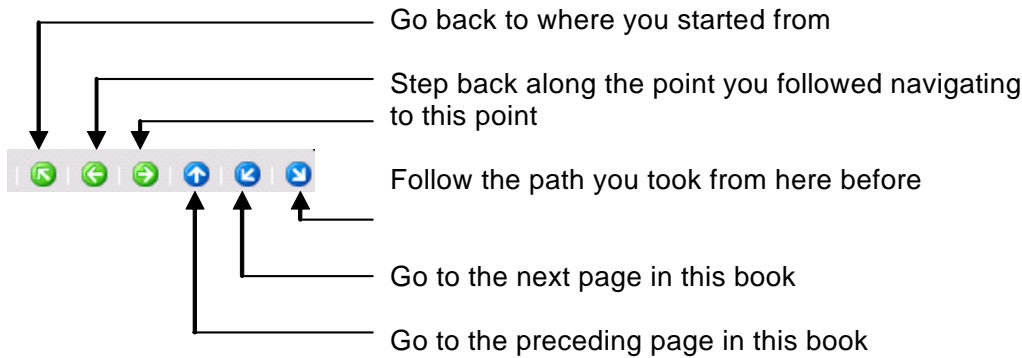

Filters

The Filter Feature allows the user to customize the data with the book to only show parts applicable to the aircraft serial number entered.

1. Filter on the Toolbar. The Click to Filter by Aircraft Serial No. is available throughout the manual. Note: be sure to enter the serial prefix (i.e., rk50, not 50).

Click to Filter by Aircraft Serial No.

Model 400/400A Illustrated Parts Catalog
MAIN LANDING GEAR INSTL

ITEM	PART NUMBER	DESCRIPTION
		MAIN LANDING GEAR INSTL
	128-810033-3	LANDING GEAR INSTL-MAIN,LJ FOR ADDITIONAL DETAILS SE 32-40-05-01
	128-810033-4	LANDING GEAR INSTL-MAIN,R FOR ADDITIONAL DETAILS SE 32-40-05-01
	810092-1	• PIN
	97602-017	• SHIM
	97602-019	• SHIM
	11107-40	• BOLT- ALTERNATE SPARE: NAS6207-40
	6207-40	• BOLT- ALTERNATE SPARE: NAS1107-40
	960D716	• WASHER- FOR SPARES ORDER: NAS1149D0763H
	1149D0763H	• WASHER- SPARES REPLACEMENT FO AN960D716

Filters

Code	Description	Value
SN	Serial No.	RK50
PSN	Parent Serial No.	
S	Superseded	undefined
SQ	Specific Query	undefined
EFFECT	Serial Effectivity	

Undo Filter

- Filter on the Main Menu. Note: this filter supplies a prefix selector. For example, to filter for Beechjet RK-50, select “RK” in the prefix drop-down and enter “50” in the serial field.

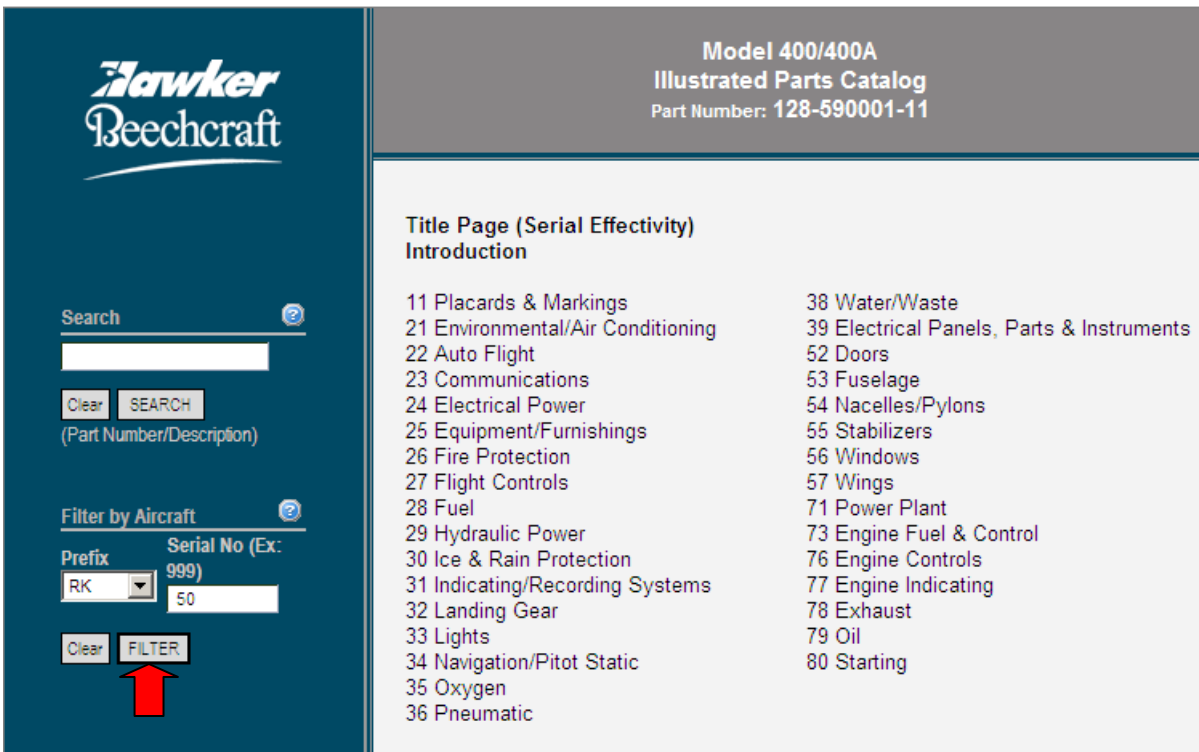

When filtering is on, a notification appears on the far right of the toolbar and remains until you have cleared or changed the filter.

Filtered for Serial Number RK50

Searches

Enter the part number or part descriptions (fragments may be used) and click **Search**. (Clicking the  provides a pop-up with how to perform searches.) The **Search For A Part** box appears with the results. Further searching may be done from this point.

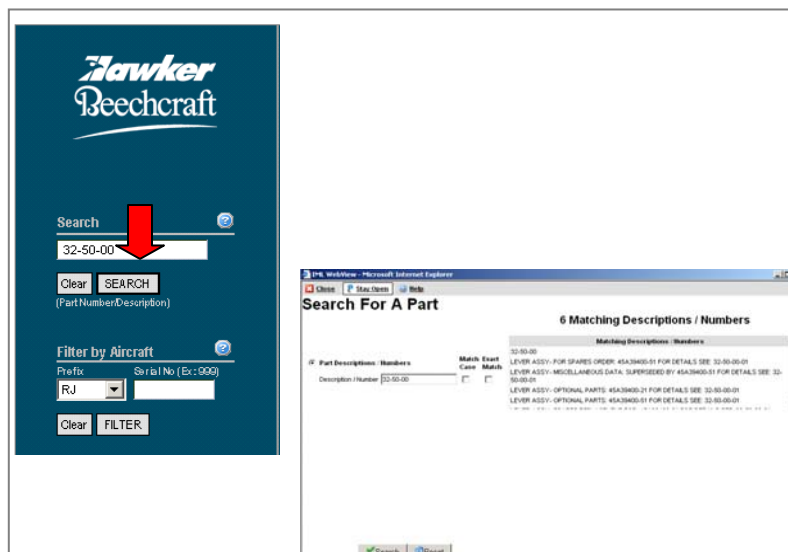

Links in IPCs and WDMs

Entries with a link icon  or underlined text indicate a built-in cross-reference that links to further details. Click to follow the link. Blue text may indicate a link or a callout on a figure.

Beechjet Model 400/400A and Hawker 400XP Model 400A - IPC

UPPER DRAG STRUT ASSY

ITEM	PART NUMBER	DESCRIPTION
	<input type="checkbox"/>	UPPER DRAG STRUT ASSY
	<input type="checkbox"/>	UPPER DRAG STRUT ASSY
	<input type="checkbox"/>	STRUT ASSY-DRAG,UPPER FOR NHA SEE: 32-20-05-01

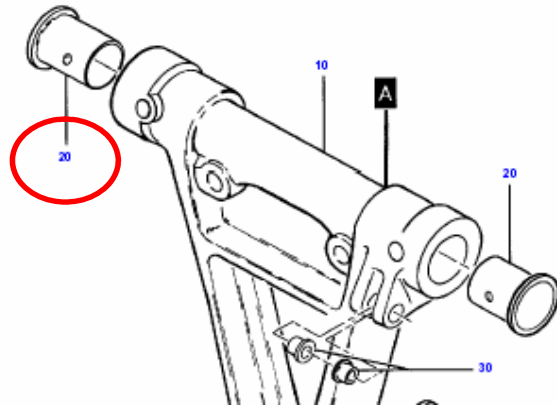

Shopping Cart

Add items to the shopping cart by checking one or more parts in the parts list then click the **Add to Cart** button.

IML WebView - Beechjet 400/400A and Hawker 400XP IPC - Microsoft Internet Explorer

Click to Filter by Aircraft Serial No.

Beechjet Model 400/400A and Hawker 400XP Model 400A - IPC

PILOTS SEAT

ITEM	PART NUMBER	DESCRIPTION
<input checked="" type="checkbox"/>	530 4676-1	. . . CUSHION-ARMREST
<input checked="" type="checkbox"/>	535 4676-2	. . . CUSHION-BACKREST
<input checked="" type="checkbox"/>	540 4675-1	. . . CUSHION-BACKREST
<input checked="" type="checkbox"/>	545 4675-11	. . . CUSHION-BACKREST
<input type="checkbox"/>	550 3085-1	. . . COVER-BOTTOM
<input checked="" type="checkbox"/>	555 4691-1	. . . COVER-ARMREST
<input checked="" type="checkbox"/>	560 4691-2	. . . COVER-ARMREST
<input type="checkbox"/>	565 4690-1	. . . COVER-BACKREST
<input type="checkbox"/>	570 45A91395-5	. . . SHROUD-INERTIA REEL
<input type="checkbox"/>	570 45A91395-7	. . . SHROUD-INERTIA REEL
<input type="checkbox"/>	570 45A91395-9	. . . SHROUD-INERTIA REEL
<input type="checkbox"/>	575 128-530224-1	. . . BRACKET ASSY-OXYGEN MASK,LH
<input type="checkbox"/>	575 128-530224-2	. . . BRACKET ASSY-OXYGEN MASK,RH
<input type="checkbox"/>	580 101-531020-9	. . . BRACKET-POST SERVICE BULLETIN: SB25-2536

Model 400/400A Illustrated Parts Catalog
PILOTS SEAT

ITEM	PART NUMBER	DESCRIPTION
<input type="checkbox"/>	530 4676-1	. . . CUSHION-ARMREST
<input type="checkbox"/>	535 4676-2	. . . CUSHION-BACKREST
<input type="checkbox"/>	540 4675-1	. . . CUSHION-BACKREST
<input type="checkbox"/>	545 4675-11	. . . CUSHION-BACKREST
<input type="checkbox"/>	550 3085-1	. . . COVER-BOTTOM
<input type="checkbox"/>	555 4691-1	. . . COVER-ARMREST
<input checked="" type="checkbox"/>	560 4691-2	. . . COVER-ARMREST
<input type="checkbox"/>	565 4690-1	. . . COVER-BACKREST
<input type="checkbox"/>	570 45A91395-5	. . . SHROUD-INERTIA REEL
<input type="checkbox"/>	570 45A91395-7	. . . SHROUD-INERTIA REEL
<input type="checkbox"/>	570 45A91395-9	. . . SHROUD-INERTIA REEL

Part Number	Description	Qty	Book	CSUF	Item	Comments
4675-1	CUSHION-BACKREST	1	Beechjet/400XP IPC	25-10-40-01	540	✘
4676-1	CUSHION-ARMREST	1	Beechjet/400XP IPC	25-10-40-01	530	✘
4676-2	CUSHION-BACKREST	1	Beechjet/400XP IPC	25-10-40-01	535	✘

- To delete an item, click on the red ✘ at the end of the part number.
- To change quantities, click in the **Qty** box and change the number.
- Click **Clear All** to remove all part numbers from the shopping cart.
- Click on the **Print** icon to print the shopping cart.
- Click **Export** to open or save the shopping cart in a .csv file for export to Excel or other spreadsheet program.
- Click the **View Cart** icon on the top menu to toggle between viewing and hiding the cart.
- Click on the part number in the shopping cart to link back to the part number location in the catalog.

Link to Hawker Beechcraft Parts & Distribution – HBP&D (formerly Rapid)

To order the parts from HBP&D, click on the **Purchase Parts** link. The HBP&D website will open and your part number information will be displayed. Follow the instructions to obtain Price and Availability.

Note: If you reach a log-in screen, you may not have set up an account with HBP&D. Return to your Profile and select Request Access under the HBC Parts tab.

USERNAME'S PAGE | R1008305 | LOGOFF

My Tools | **HBC Parts** | Global Service & Support | Supply Chain | Misc. | User Profile

HBC Parts is here to fulfill all of your parts and support needs. Whether you own or operate a piston, turboprop, or jet, HBC Parts' mission is to provide you with unparalleled service coupled with competitive pricing on all Beechcraft and Hawker parts.

[Request Access](#)

Graphics

Figure illustrations appear in the left window. There are some differences between how IML CD users and online users Pan or Zoom graphics:

Panning

- **Online Users** – Press the Alt-Key and Hold down the left mouse button. A hand appears for you to drag the graphic around the window. (**NOTE:** You can let go of the Alt-key once you are pressing and holding down the left mouse button.)
- **CD Users** – Hold down the right mouse button to pan (move the graphic around the graphic window after zooming in).

Scroll Bars

- **Online Users** - Vertical and Horizontal Scroll Bars are not available in the Web View version of the manuals. Use the Panning capability.
- **CD Users** - When the graphic is zoomed larger than the original full-size view Vertical and Horizontal Scroll bars on the Graphic window are available for moving around the face of the graphic.

Zooming

- **Online Users** - Press the **Ctrl-Key** and **Hold down the left mouse button**. A magnifier glass with a + appears. Draw a box around the area you want to zoom. To print zoomed areas, see Appendix 1: Printing of this User's Guide.
- **CD Users** - Hold down the left Mouse button and draw a box around the area you want to zoom.

Zoom Toolbar

- **Online Users** - View > Zoom Fit / In / Out This menu controls zooming on the picture in the picture frame. Zooming in can also be performed by double-clicking on the picture. Zooming out can also be performed by holding down the control-key and double-clicking. Zoom to fit zooms the picture to exactly fit the current size of the frame.
- **CD Users** – Unavailable

Shortcut Menu

- **Online Users** - Right mouse click on the graphic for menu: Zoom In (Ctrl+Drag Mouse) – Zoom Out Original View.
- **CD Users** - Click Zoom on the Menu bar for Zoom Levels. **NOTE:** Shortcut Menus are unavailable in the CD version of IML.

Notes and Bookmarks

Notes and bookmarks available in the CD-ROM version are unavailable at this time in IML Online Manuals.

Appendix 1: Printing

IML Online Manuals can be printed as follows:

Parts Catalog Figures print best through the IML *Print Viewer*. Parts Lists print best by building a Parts Shopping Cart List and printing/saving the list.

Portable Document Formatted (PDF) documents are viewed and printed with Adobe Reader.

IML Maintenance Manuals can be printed using either the built-in *Print Viewer* or the Internet Explorer Print Function.

Using Internet Explorer Print Function is in most cases the easiest method.

Instructions are given for both Printing methods.

Printing One Figure Using Internet Explorer (prints the figure title)

1. Close the Text window by Clicking Display and selecting Parts to toggle the text window “off”.
2. This will allow the Picture window to expand and fill the entire screen. Select the Figure desired from the drop down box so that it shows on your screen.
3. On your Internet Explorer menu bar click File > Print Preview.
4. Change the Page View to 2 page view and desired Paper Orientation. (Drawing appears on page 2).
5. Click the print button and Select Page Range Pages: 2
6. Click Print.
7. Click Display and select Parts to toggle the text window back “on”.

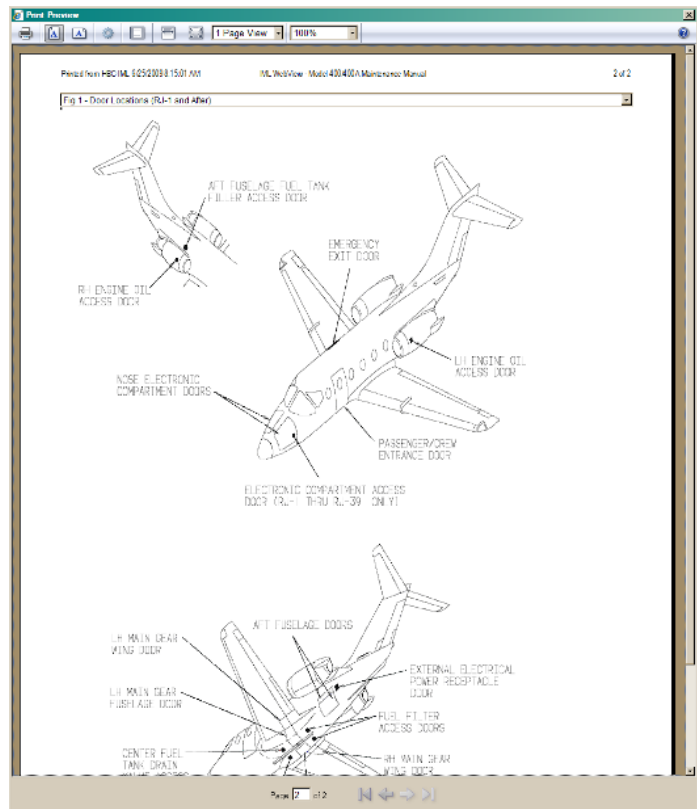
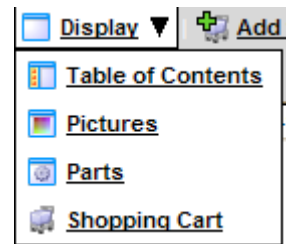

Printing Zoomed Figure Using Internet Explorer (prints the figure title)

1. Close the Text window by Clicking Display and selecting Parts to toggle the text window “off”.
2. This will allow the Picture window to expand and fill the entire screen. (To get your text window back, Click Display and select Parts to toggle the text window “on”).
3. Select the Figure desired from the drop down box so that it shows on your screen.
4. Ctrl+Left Mouse Button to get Magnifying Tool. Draw Box around area you wish to enlarge for printing.
5. Alt+Left Mouse Button to get Hand Tool for moving picture around the screen for best view – Center the enlarge section on the screen for best printout.
6. On your explorer menu bar click File > Print Preview
7. Change the Page View to 2 page view.
8. Select paper orientation.
9. Change from ‘Shrink to Fit’ to 100%.
10. Click the print button.
11. Select Page Range Pages: 2 and Print.

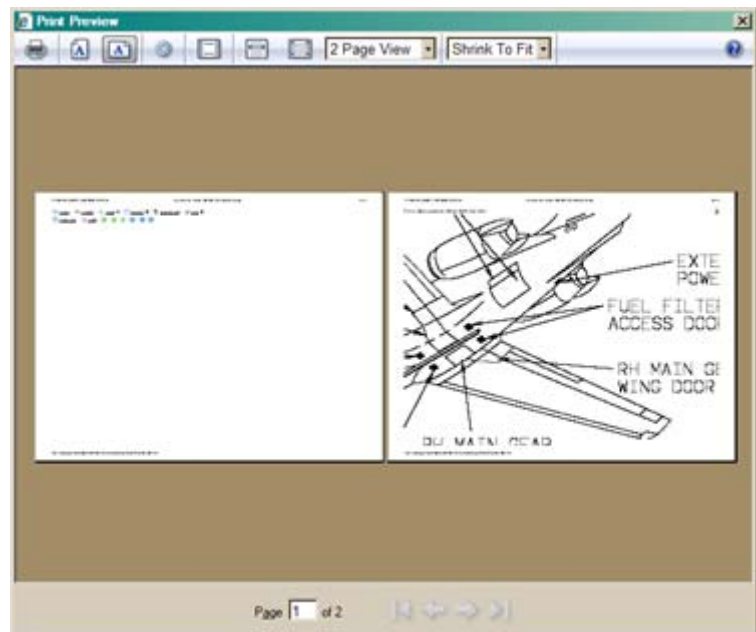
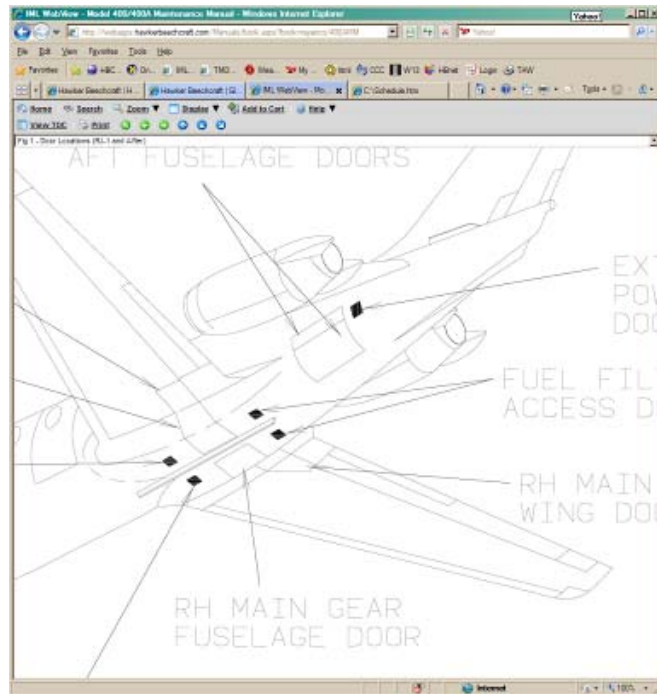
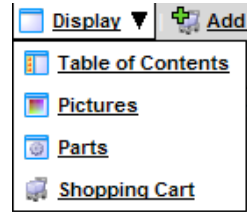

Printing Text Using Internet Explorer

1. Right click on the text (Prints ALL Text).
2. Click Print Preview... This allows you to preview the pages and print all of the pages or selected pages.

NOTE: Selected text printing is currently unavailable. Copy/Paste selected text from the online version to Word or other text editing software. **If copy/paste is used, you are responsible for all Warnings, Cautions, Notes and Procedures associated with any uncopied text/figures that are associated with the selected text.**

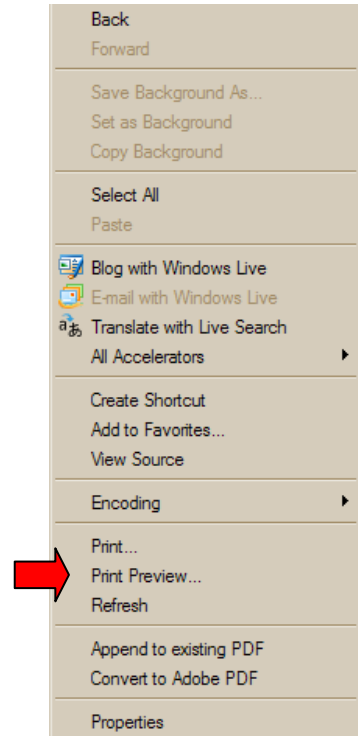

The screenshot shows the 'Print Preview' window of Internet Explorer. The document content includes sections for 'ACCESS (SERVICE) DOORS', 'AFT FUSELAGE DOOR OPERATION', 'CABIN ENTRANCE/AFT FUSELAGE DOOR WARNING SYSTEM', 'LANDING GEAR DOORS', and 'RECOMMENDED MATERIALS'. The 'RECOMMENDED MATERIALS' section contains a table with 4 columns: MATERIALS, SPECIFICATION, PRODUCT, and SUPPLIER / WEB SITE.

MATERIALS	SPECIFICATION	PRODUCT	SUPPLIER / WEB SITE
1. Rubber Plate	MIL-R-6855 Class 2, Grade 80		O stain locally.
2. Cement	MIL-C-4003		O stain locally.
3. Solvent		Methyl Propyl Ketone (MPK)	O stain locally.
4. Solvent	TTN-95	Naptha	O stain locally.
	TT-T-548	Technical Toluene	O stain locally.

At the bottom of the window, it says 'Page 2 of 3' and has navigation arrows.

Printing from the Built-in IML Print Viewer

KEY: Print Jobs from the IML *Print Viewer* are always sent as two separate Print Jobs.

- Figures are sent first followed by Text.
- Figure Printing is controlled by the first Print Dialog Box that appears.
- Text Printing is controlled by the second Print Dialog Box.
- You can choose to print or cancel printing either the figure(s) or the text jobs.

NOTE: The Figure Print Dialog will open even if the document you are printing does not have any figures. If you Click Print you will get a blank page with header information.

The second Print Dialog Box appears when the first job is either canceled or printed and sends the text which you can choose to either print or cancel the text printing.

If the document has Figures, the figure showing in the document's picture window when the IML Print Button is clicked displays in the *Print Viewer* along with the documents text/parts list.

Click **Print** on the IML Menu Bar to Open the *Print Viewer*.

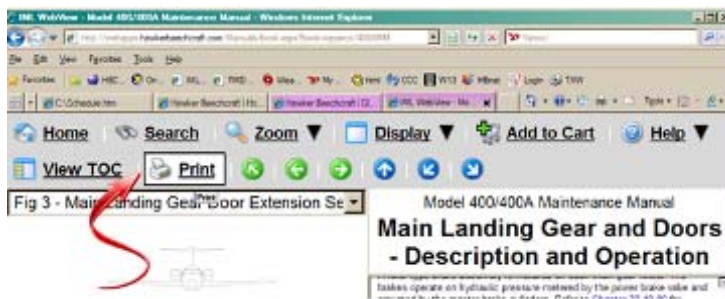

Notice Text and the Figure(s) are no longer displayed side-by-side.

The *Print Viewer* displays Figure(s) and Text in vertical windows. The figure and text windows are connected by a scroll bar and separated by horizontal line(s). The Text Window falls below the figure(s) window(s) and contains it's own scroll bar to scroll the text.

Print Viewer Menu Bar Settings

- ◆ Close – Exits the *Print Viewer*
- ◆ Print – Opens Print Dialog Boxes
- ◆ All Pictures – Displays All Figures in the current document for printing.

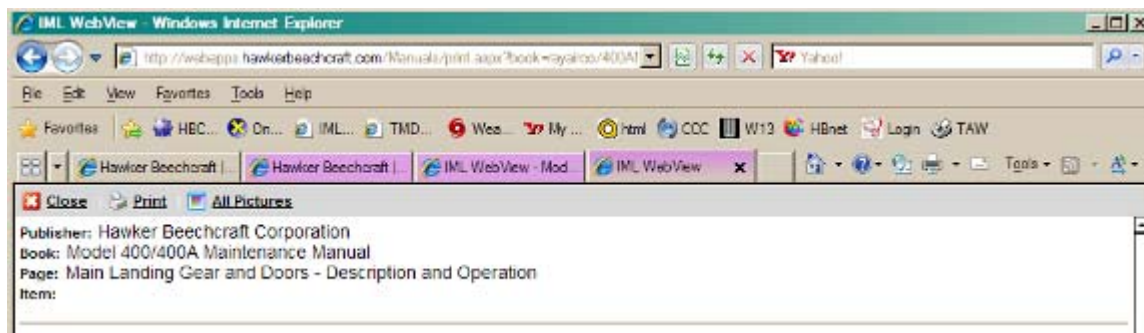

CAUTION: Hyperlinks are not active in the *Print Viewer* windows. If you click a link in the *Print Window* You get an error that the webpage cannot be displayed. If this occurs, close the error message window to go back to the IML document and Start Over.

Printing Figure(s) and Text

Only the Figure printouts display the source of the document on the first page of the print job as follows:

Publisher: Hawker Beechcraft Corporation
Book: Model and type of Manual (i.e. Model 400/400A Maintenance Manual)
Page: Title of the Page (i.e. Main Landing Gear and Doors - Description and Operation)
Item:

NOTE: ATA, Figure Numbers and Figure Titles do not print at this time.

Printing One Figure With or Without Text

If you want to print one figure in particular out of several in a document, that Figure has to be displayed in the document's picture window at the time of printing.

Select the Figure you want to print from the Figure Drop Down box containing Figure Numbers and Titles located above the Figure Window.

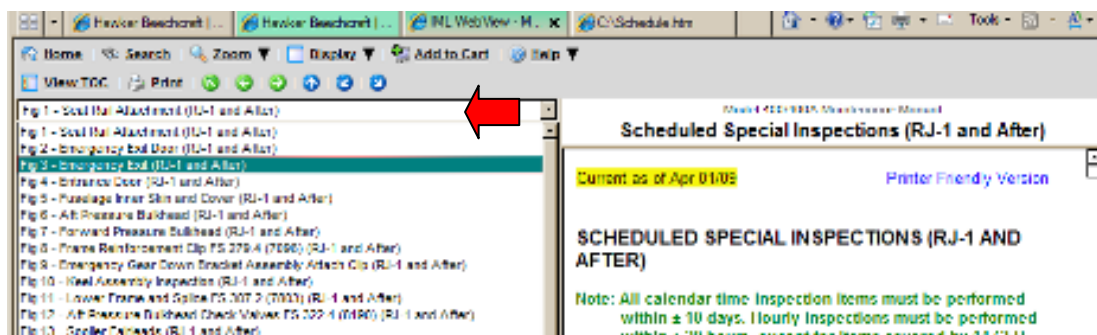

Click Print on the IML Menu Bar.

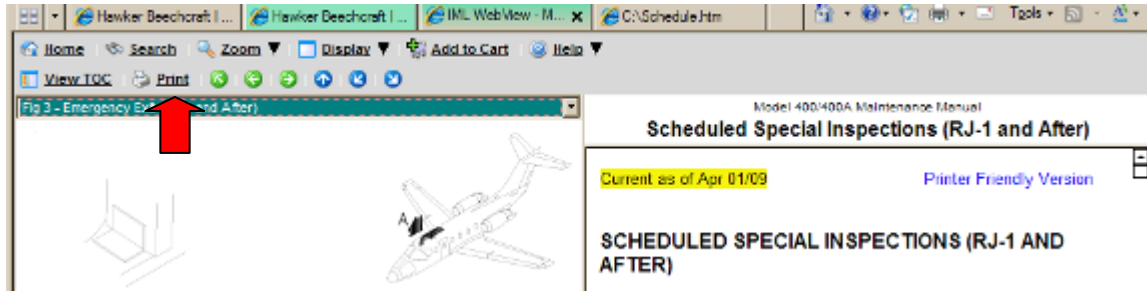

Click Print on the *Print Viewer* Menu

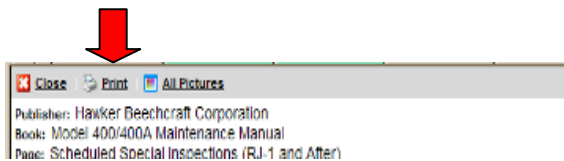

Print Dialog Box for Figures opens

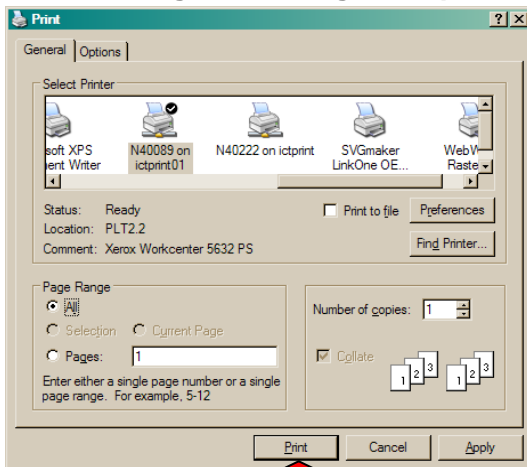

Click Print

WITHOUT TEXT

A **Second** Print Dialog Box Opens for printing the text after the Figure Print Job has gone to print. **If you do NOT want to print the text Click Cancel for the second Print Dialog Box.**

WITH ALL OF THE TEXT

If you want to print the text and the Picture then **Click Print on the Second Print Dialog Box.**

WITH ALL TEXT – WITHOUT FIGURE(S)

Cancel the first Print Dialog Box. The second dialog box prints the text.

Printing All of the Figures With or Without Text

When printing ALL of the figures it doesn't matter which figure is currently displayed in the document picture window.

Click **Print** on the **IML Menu Bar** to open the *Print Viewer*.

Click **All Pictures Button** to import all of the figures

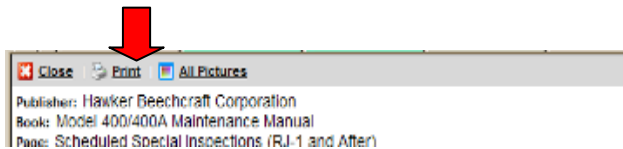

Click **Print** on the *Print Viewer* Menu

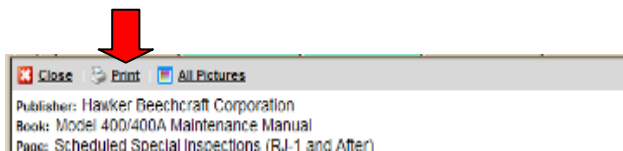

Print Dialog Box for Figures opens

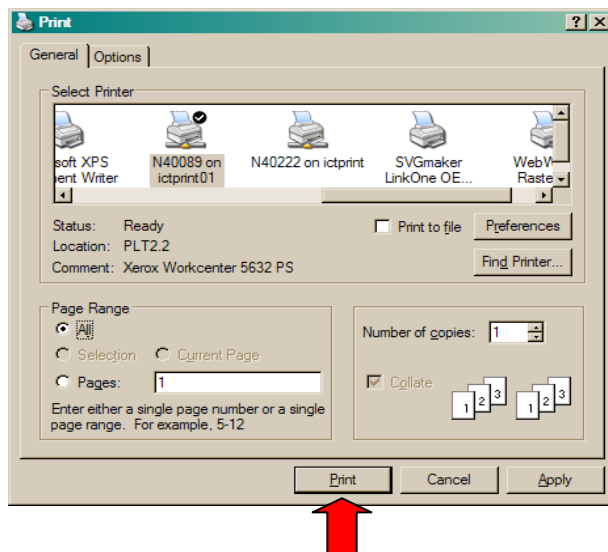

WITHOUT TEXT

A **Second** Print Dialog Box Opens for printing the text after the Figure Print Job has gone to print. **If you do NOT want to print the text Click Cancel for the second Print Dialog Box.**

WITH ALL OF THE TEXT

If you want to print the text and the Picture then Click Print on the Second Print Dialog Box.

Printing a Zoomed View from the Print Viewer

If you zoom a picture in the document picture window prior to clicking the Print button the picture will not appear in the Printer View as a zoomed picture.

Select the Figure you want to ZOOM from the Figure Drop Down box above the Figure Window. **Do NOT Zoom in on the picture at this time.**

Click Print on the IML Menu Bar.



Find the area on the Figure you want to enlarge. **HINT: Press the Alt-Key and Hold down the left mouse button.** A hand appears for you to drag the graphic around the window to desired area.

Press the **Ctrl-Key** and **Hold down the left mouse button.** A magnifier glass with a + appears. Draw a box around the area you want to zoom.

NOTE: Right click anywhere on the picture and select Original View to return to full-sized picture.

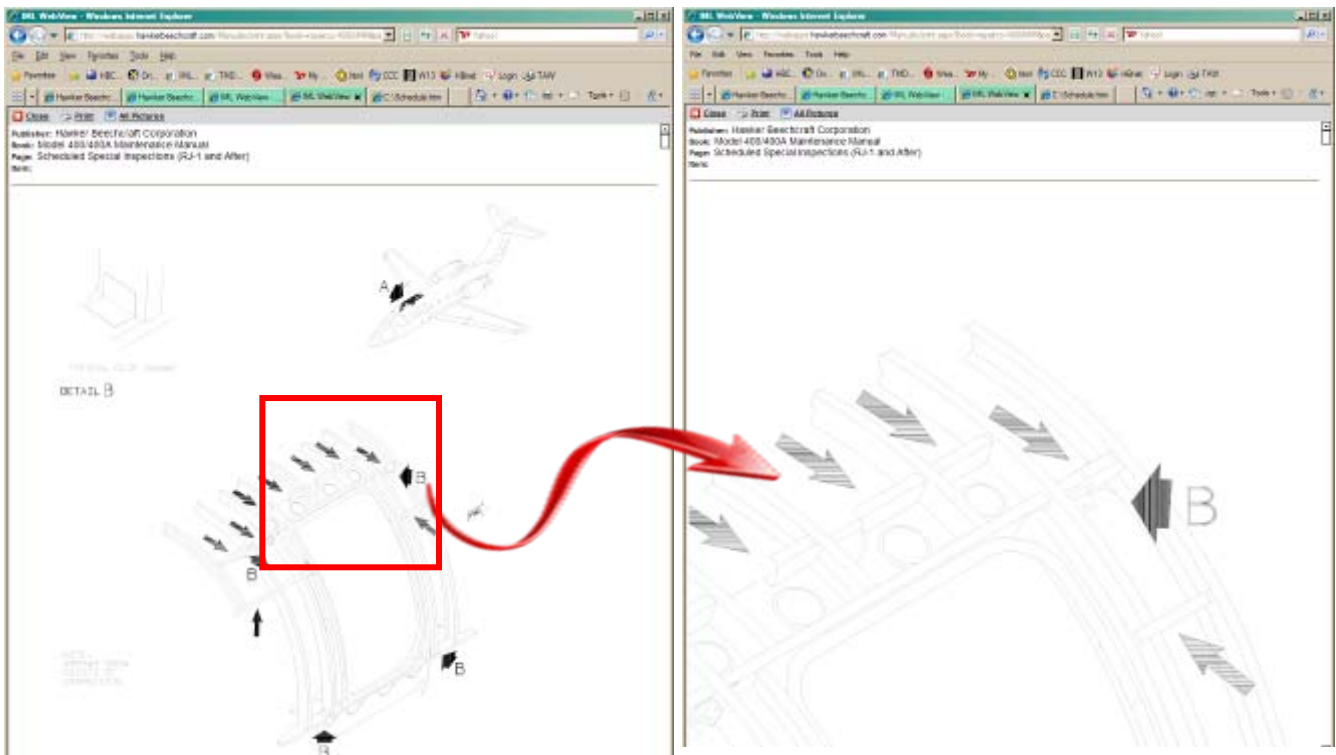

Click Print on the *Print Viewer Menu*

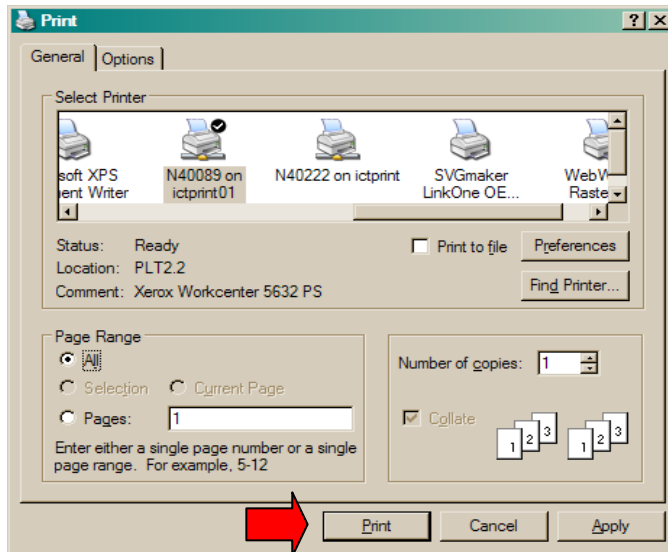
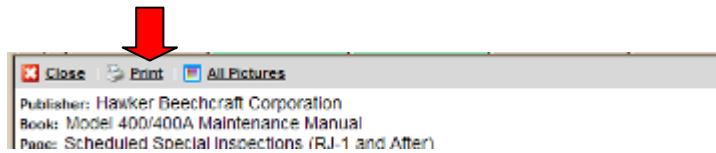

Remember, a Second Print Dialog Box will open for printing the text after the Figure Print Job has gone to your printer. **If you do NOT want to print the text Click Cancel.**

NOTE: If you want the text with the Zoomed figure then Click Print on the Second Print Dialog Box.

Click Print

Printing Text

Printing Text and Figures

Follow the Instructions above for printing any figure configuration (*One Selected Figure, All Figures, Zoomed Figure*) and Click Print on the Second Print Dialog Box that prints text.

Printing Text Only (No Figures)

Follow the Instructions above for printing one figure and cancel the first Print Dialog Box that prints figures.

Appendix 2: Contact/Help Line Information

Technical Manual Distribution Center Manual Sales & Subscriptions	Interactive Maintenance Libraries/ Online Manuals
Monday through Friday 8:00 am to 4:30 pm Central time (Note: during off-hours, leave a voicemail or email message and your inquiry will be addressed within one business day.)	
800.796.2665 toll free 316.676.8238 local/international 316.671.2540 fax tmdc@hawkerbeechcraft.com e-mail	800.240.2959 toll free 316.676.3053 local/international 316.676.6706 fax IML@hawkerbeechcraft.com e-mail
http://pubs.hawkerbeechcraft.com	

How To Articles detailing specific features/functions are available at:
https://www.hawkerbeechcraft.com/customer_support/technical_publications/iml_support/ (Click the **How-To Documents**). Additional IML support is also available on this site. Questions can be submitted by clicking on **Submit a Question**.

The screenshot shows the Hawker Beechcraft website interface. At the top, there is a navigation bar with links like 'FLY SMART HAWKER', 'SUCCESS DEFINED BEECHCRAFT', 'CUSTOM CAPABILITIES MILITARY + SPECIAL MISSION', 'HAWKER BEECHCRAFT PRE-OWNED', 'GLOBAL CUSTOMER SUPPORT', and 'PURCHASE PARTS'. A search bar is located in the top right corner. The main content area is titled 'Technical Publications' and 'IML Software Support'. Below this, there is a search form with dropdown menus for 'Select Product Type...', 'Select Model...', and 'Select Manual Type...', followed by an 'Enter Part Number...' field and a 'Search' button. A 'Cart (0 Items)' icon and 'My Pubs Account' link are also visible. A sidebar on the left contains a list of links, including 'Overview', 'HBC Parts & Distribution', 'Hawker Beechcraft Services', 'Authorized Service Centers', 'Technical & Field Support', 'Support Plus', 'Technical Publications', 'Warranty', 'Events Schedule', and 'Accounts Payable'. A red arrow points to the 'How-To Documents' link in the sidebar. Below the sidebar, there is a 'How To Documents' section with a list of articles, each with a date and a brief description.